

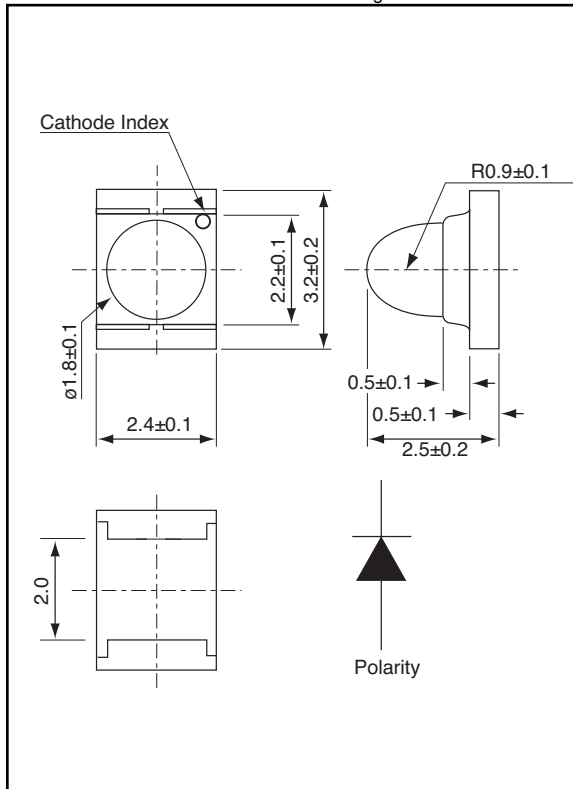

Weight: 2.0 Unit: mm



Product specifications contained herein may be changed without prior notice. It is therefore advisable to contact Purdy Electronics before proceeding with the design of equipment incorporating this product.

AND5BA

GaN Ultra Bright Blue Light Emission Surface Mount Package

Features

- Small package size with dome lens
- 3.2 (l) x 2.4 (w) x 2.6 (h) size
- Suitable for REFLOW soldering
- Recommended Forward Current: 10 mA
- RoHS Compliant

Maximum Ratings ($T_a = 25^\circ\text{C}$)

Characteristics	Symbol	Rating	Unit
Forward Current	I_F	30	mA
Reverse Voltage	V_R	4	V
Power Dissipation	P_D	100	mW
Operating Temperature Range	T_{Opr}	-30 to 85	$^\circ\text{C}$
Storage Temperature Range	T_{Stg}	-30 to 90	$^\circ\text{C}$

Electro-Optical Characteristics ($T_a = 25^\circ\text{C}$)

Characteristics	Symbol	Test Condition	Minimum	Typical	Maximum	Unit
Forward Voltage	V_F	$I_F = 20$ mA	–	3.8	4.5	V
Reverse Current	I_R	$V_R = 4$ V	–	–	100	μA
Luminous Intensity	I_V	$I_F = 20$ mA	90	112	–	mcd
Peak Emission Wavelength	λ_P	$I_F = 20$ mA	–	430	–	nm
Spectral Line Half Width	$\Delta\lambda$	$I_F = 20$ mA	–	65	–	nm
Dominant Wavelength	λ_d	$I_F = 20$ mA	–	450	–	nm
Full Viewing Angle	θ	$I_V = 1/2$ Peak	–	30	–	degree

Precaution

Please be careful of the following:

1. Manual soldering: maximum temperature of iron tip: 260°C max.
Soldering time: within 5 sec. per solder-land
Soldering portion of lead: up to 1.6 mm from the body of the device
2. Reflow solder: recommended condition is as follows:

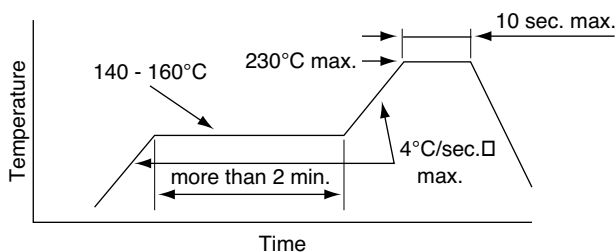

3. Absolute secure counter measures against static electricity and surge should be taken when handling these products. It is recommended to use wrist band or antistatic gloves when handling these LEDs.

The following soldering patterns are recommended for reflow soldering

